

Features

Supports a 2x1 arrangement of Hamamatsu S13361-3050AE-08 8x8 3mm arrays for a total of 16x8 MPPCs

Signal connectors located on the back
SiPM arrays located on the front

3-side tileable installation

Four encoded position signals for event centroid calculations: X+, X-, Y+, Y-

DC-coupled signal path

Low power consumption

Sum output with adjustable gain

Patented diode-coupled charge division readout, superior to traditional resistive readout

Improved spatial uniformity

Faster rise time

Reduced image noise

Precision temperature sensor

Four mounting holes for #4 or M3 hardware

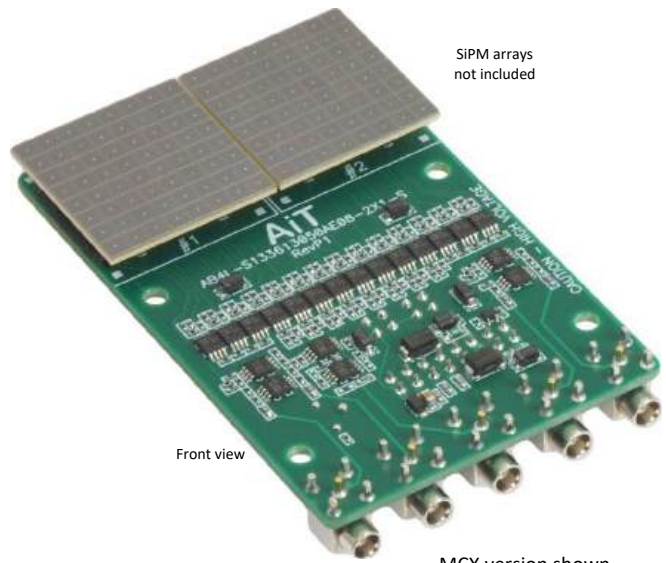

Part Number

AB4L-S133613008-2X1-S-P/N-XXXX

-P/N: P = Positive output signal polarity
N = Negative output signal polarity
XXXX: MCX, SMA, SMB, LEMO

Example: AB4L- S133613008-2X1-S-P-MCX

Positive output signal polarity, MCX connectors

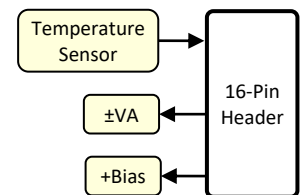
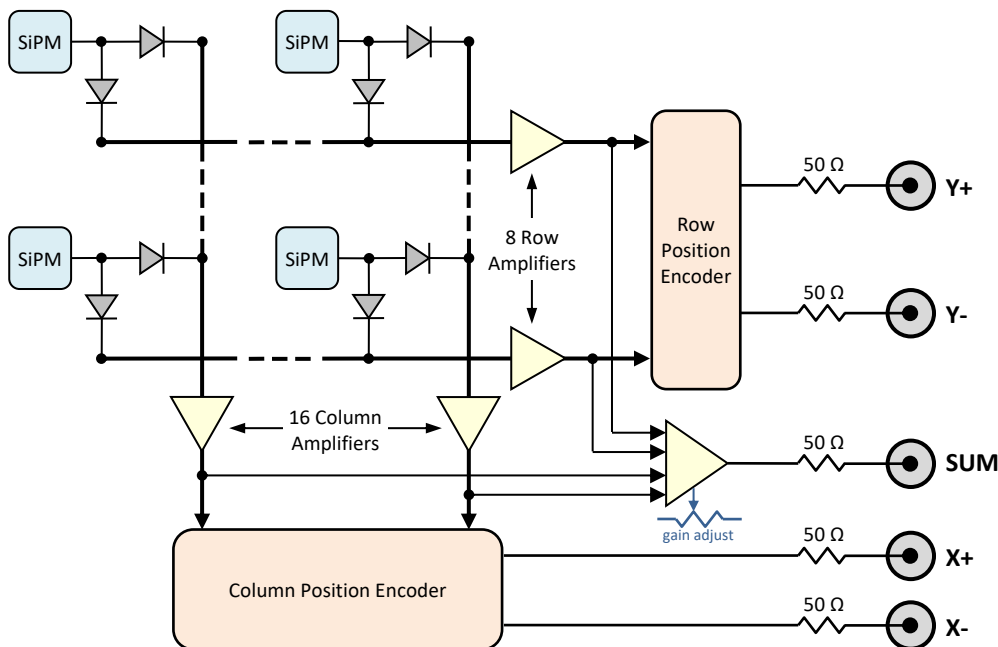

Compatible with the AiT Amplifier Board Power Supply (model ABPS)

Channel Map

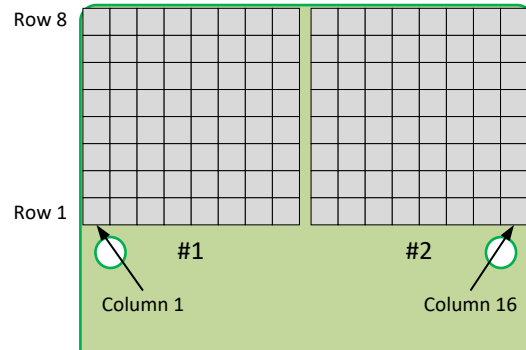

POWER Connector

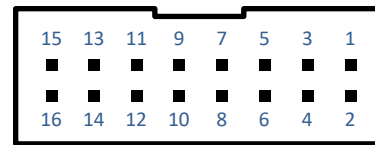

Pin	Function	Pin	Function
1	+VA	2	+VA
3	Ground	4	Ground
5	-VA	6	-VA
7	Ground	8	Ground
9	+VA Monitor	10	Ground
11	-VA Monitor	12	Ground
13	Temperature	14	Ground
15	Bias	16	Ground

x0 → x1 (row + column sum)
25-turn potentiometer

Temperature Sensor

68V Zener diode
375mW maximum
NOTE: Zener clamp is connected to the POWER connector, not the EXT BIAS connector

Amplifier Voltage (±VA) ±2.8V → ±5.1V maximum

Current ±70mA typical
(I_q, no signal, no load)

Voltage clamp ±5.1V Zener diode

Signal Connectors 50Ω coaxial options:
MCX, SMA, SMB, LEMO

Power Connector Vertical 16-pin 2-row shrouded header, 0.1" pin pitch

EXT BIAS Connector

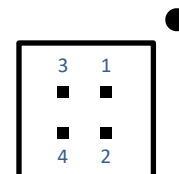

Pin	Function	Pin	Function
1	Ground	2	Array #1 bias
3	Ground	4	Array #2 bias

4-Channel Position Encoder

Column Encoder Weights

Column# for X-	Column# for X+	Fraction ideal	Fraction actual	% Error	Notes
1	16	0.0625	0.0625	0.00 %	Sum of X- and X+ fractions = 1.0625 Independent of signal position
2	15	0.1250	0.1250	0.00 %	
3	14	0.1875	0.1861	-0.75 %	
4	13	0.2500	0.2483	-0.68 %	
5	12	0.3125	0.3158	1.06 %	
6	11	0.3750	0.3731	-0.51 %	
7	10	0.4375	0.4412	0.85 %	
8	9	0.5000	0.5000	0.00 %	
9	8	0.5625	0.5618	-0.12 %	
10	7	0.6250	0.6250	0.00 %	
11	6	0.6875	0.6818	-0.83 %	
12	5	0.7500	0.7500	0.00 %	
13	4	0.8125	0.8021	-1.28 %	
14	3	0.8750	0.8876	1.44 %	
15	2	0.9375	0.9375	0.00 %	
16	1	1.0000	1.0000	0.00 %	

Row Encoder Weights

Row# for Y-	Row# for Y+	Fraction ideal	Fraction actual	% Error	Notes
1	8	0.1250	0.1250	0.00 %	Sum of Y- and Y+ fractions = 1.1250 Independent of signal position
2	7	0.2500	0.2483	-0.68 %	
3	6	0.3750	0.3731	-0.51 %	
4	5	0.5000	0.5000	0.00 %	
5	4	0.6250	0.6250	0.00 %	
6	3	0.7500	0.7500	0.00 %	
7	2	0.8750	0.8876	1.44 %	
8	1	1.0000	1.0000	0.00 %	

Note: Errors exclude component tolerances

Output Signals

$$\begin{aligned}X^- &= (\text{SiPM signal}) * (\text{encoder gain}) * (X^- \text{ fraction}) \\X^+ &= (\text{SiPM signal}) * (\text{encoder gain}) * (X^+ \text{ fraction}) \\Y^- &= (\text{SiPM signal}) * (\text{encoder gain}) * (Y^- \text{ fraction}) \\Y^+ &= (\text{SiPM signal}) * (\text{encoder gain}) * (Y^+ \text{ fraction})\end{aligned}$$

Typical event position calculation:

$$\begin{aligned}\mathbf{X \text{ column}} &= (X^+ - X^-) / (X^+ + X^-) \\ \mathbf{Y \text{ row}} &= (Y^+ - Y^-) / (Y^+ + Y^-)\end{aligned}$$

Example

SiPM signal at column 4, row 3 (excluding encoder gain)

$$\begin{aligned}X^- &= (\text{Column 4 signal}) * 0.2483 \\X^+ &= (\text{Column 4 signal}) * 0.8021\end{aligned}$$

$$\begin{aligned}Y^- &= (\text{Row 3 signal}) * 0.3731 \\Y^+ &= (\text{Row 3 signal}) * 0.7500\end{aligned}$$

Typical Signals

Positive output polarity option

Source = Laser; Position signal; Bias = +55V

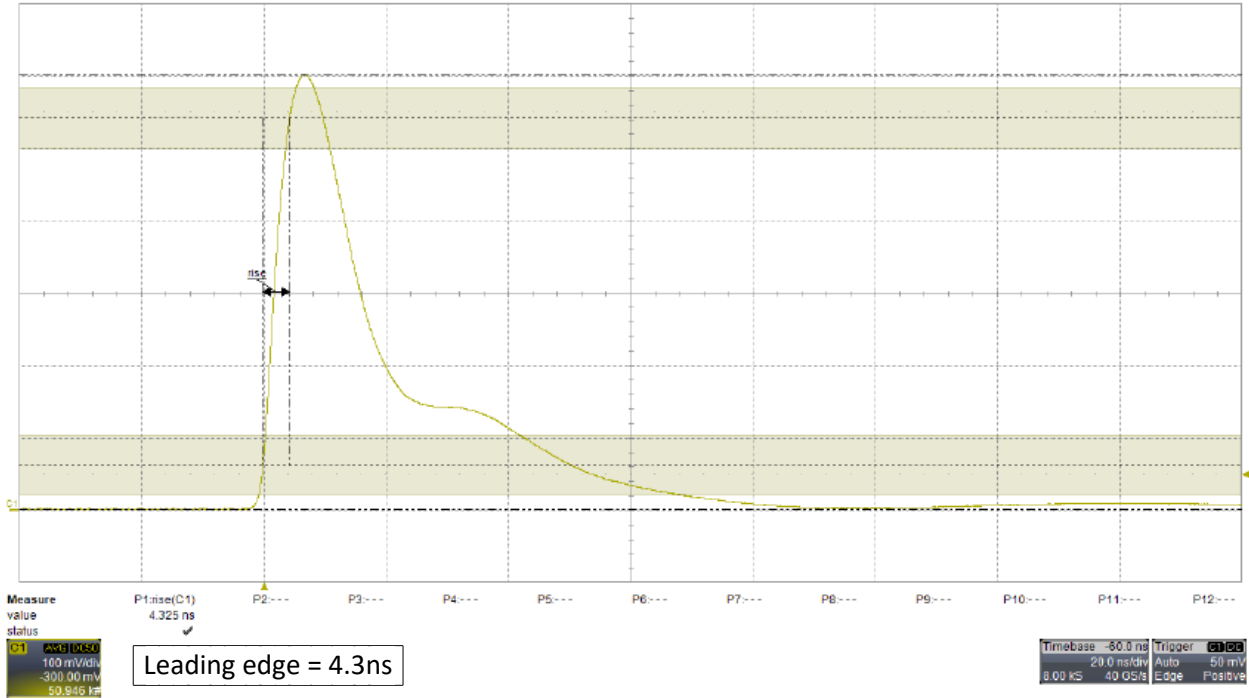

Source = LYSO; Position signal; Bias = +55V; Persistence display

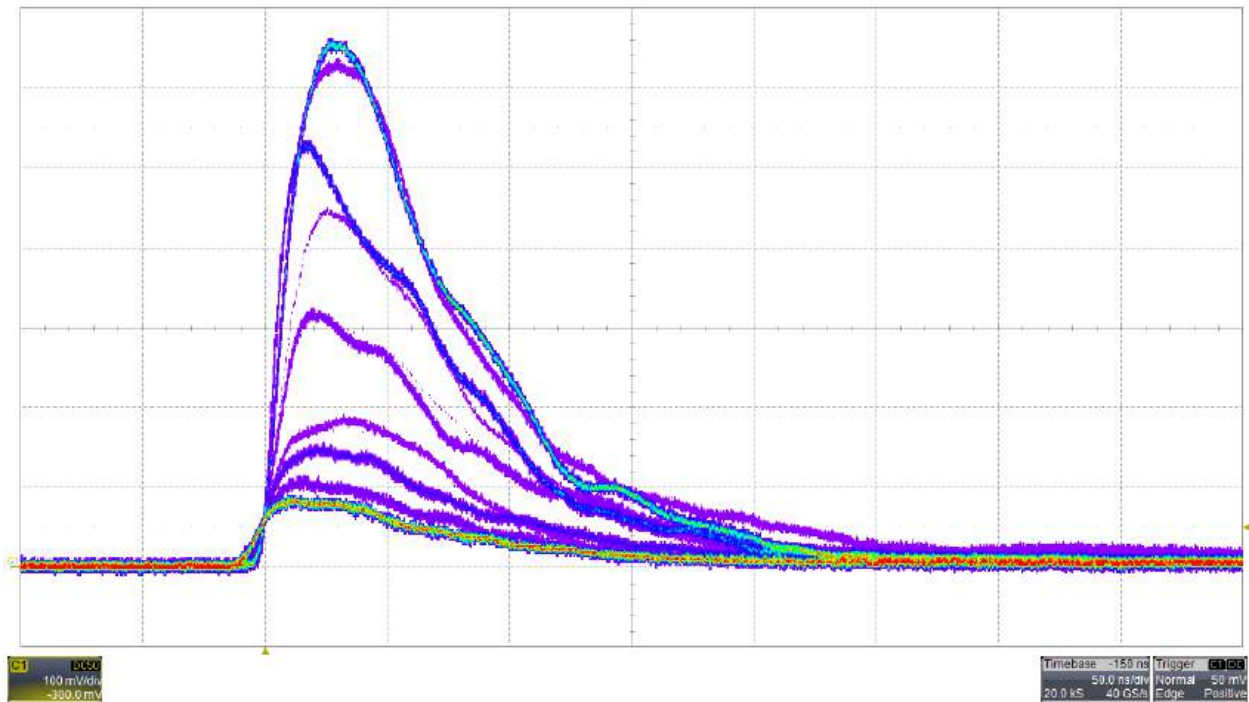

Mechanical

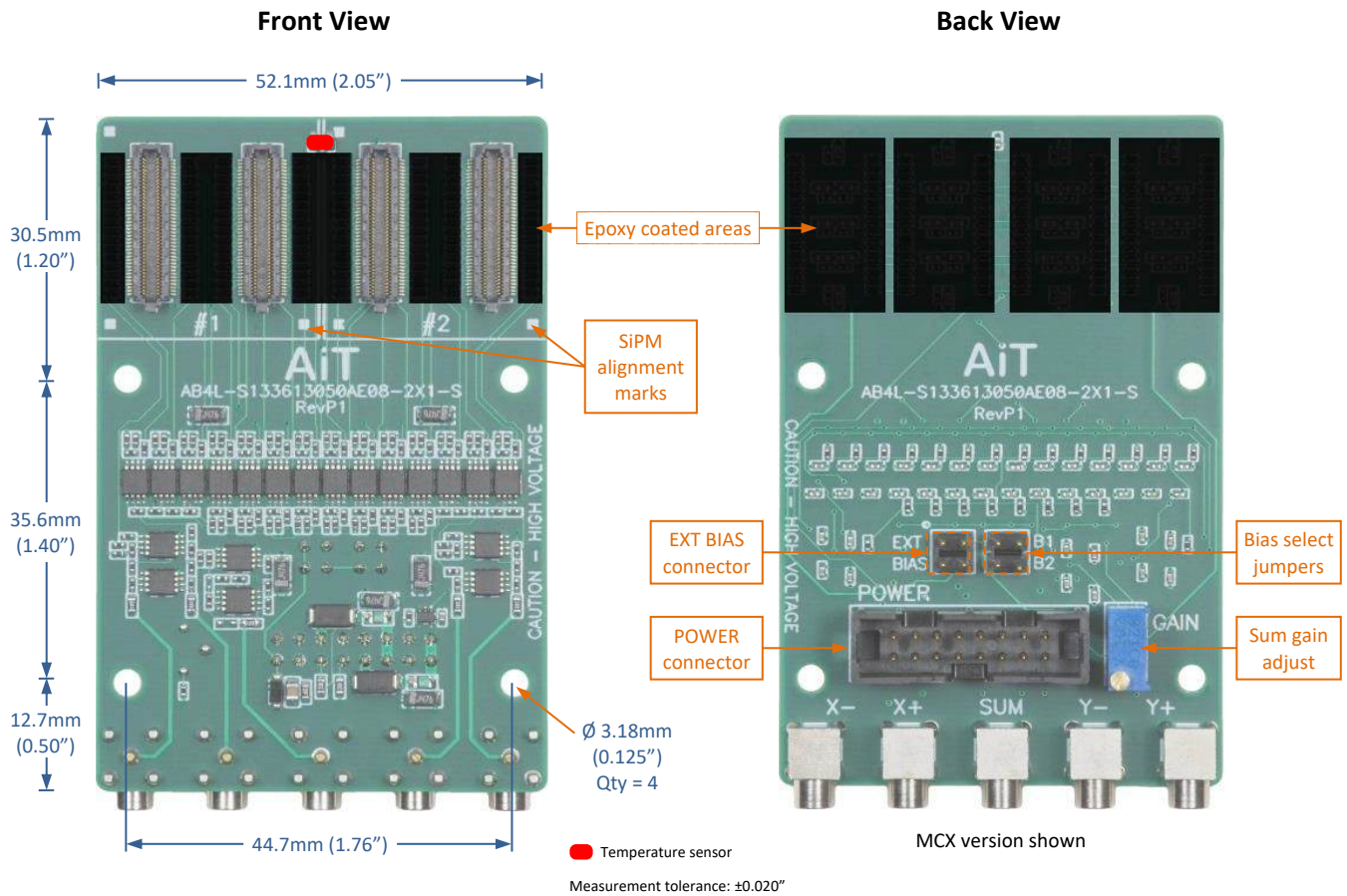

Array Locations

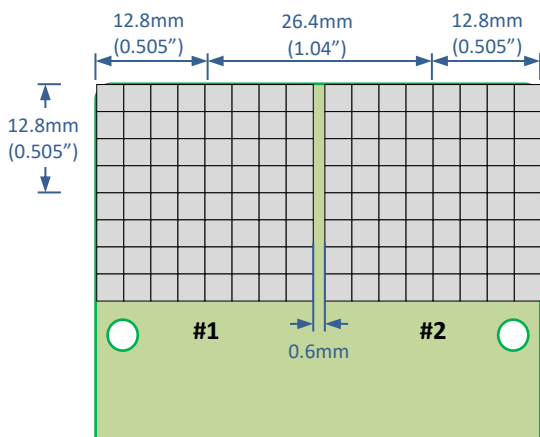

Bias Select Jumpers

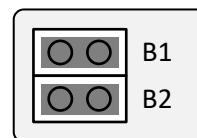

Install jumper B1 to connect POWER connector bias voltage to Array #1.

Install jumper B2 to connect POWER connector bias voltage to Array #2.

Install B1 and B2 to apply POWER connector bias to both arrays.

Remove B1, B2, or both jumpers to apply separate bias voltages on the EXT BIAS connector.

Array Installation Guide

STEP 1

Install arrays by inserting the outer connectors first, one array at a time.

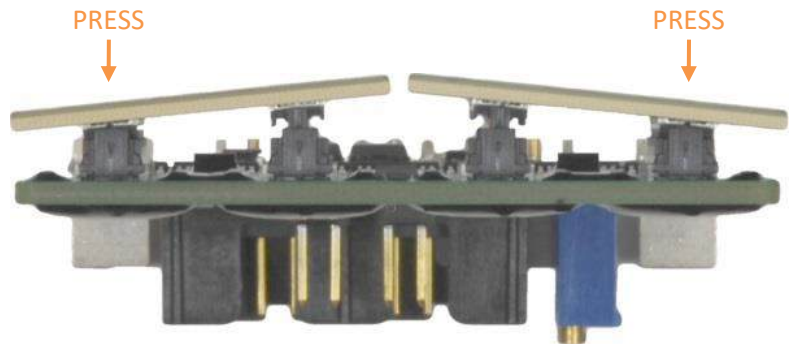

STEP 2

Press the arrays to insert the inner connectors.

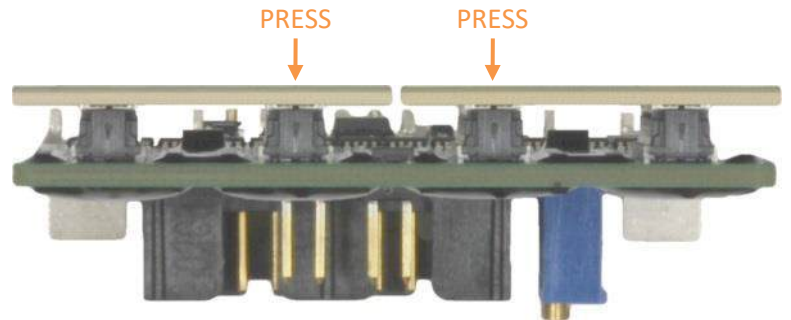

Array Removal

To remove the arrays, reverse the installation procedure. Pull up the connectors labeled **PRESS**, one array at a time. Always pull up the inner connectors first.

CAUTION

Avoid inserting the inner connectors first or removing the outer connectors first because this may cause the array surfaces to touch. The array resin surfaces may be lightly touched together without damaging the silicon. However, excessive force can damage the resin and risk damaging the silicon.

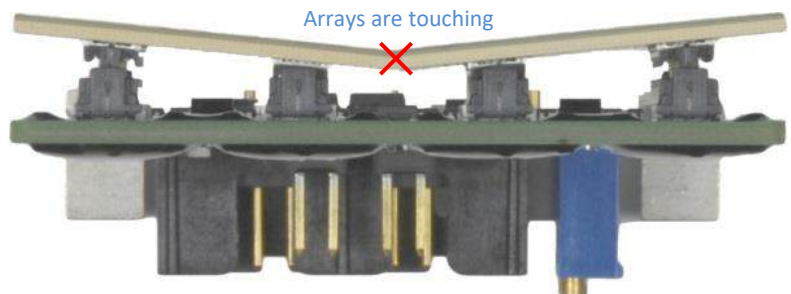

Avoid inserting inner connectors first
Avoid pulling up outer connectors first

Safety Information



WARNING – High Voltage

High voltage may be present during operation
High voltage stored on capacitors may be present after power is removed
Improper handling may result in personnel injury or equipment damage

This high-voltage device must be used only by personnel trained and qualified in safe handling, installation, and operation of high-voltage equipment.



CAUTION – Electrostatic Discharge (ESD) Sensitivity

The circuit board can be damaged by electrostatic discharge. Observe precautions for handling electrostatic sensitive devices. Handle only at static-safe workstations.

High-Gain Photodetectors

High-gain photodetectors such as silicon photomultipliers may conduct damaging currents if exposed to high optical signal levels while the bias voltage is applied, or if the bias voltage exceeds the recommended operating range. These devices must be operated only in low-light conditions, and only within the manufacturer's recommended bias voltage range.

Handling and Disassembly

This product may be provided with a protective enclosure. Disassembled enclosure components and circuit boards may contain sharp edges. Take appropriate safety precautions while assembling or disassembling the enclosure and handling disassembled components.

Indoor Use Only

Do not operate this product in a wet or damp environment. Do not operate in an explosive atmosphere.

Use of this product, and AiT Instruments' liability related to use of this product, is further governed by AiT Instruments' standard terms and conditions of sale, which were provided upon purchase of this product.